

MXIPV FD81334V

Fixed Dome Network Camera

1MP | Vandal-proof | IP66



Maxcom's FD8133V(Wired)/34V(PoE) is an easy-to-use fixed dome network camera specifically designed for indoor/outdoor security applications with a compact, stylish vandal-proof exterior. Equipped with a 1MP sensor enabling viewing resolution of 1280x800 at 30 fps, users need look no further for an all-in-one camera capable of capturing high quality, high resolution video.

The FD8133V/34V supports the industry-standard H.264 compression technology, drastically reducing file sizes and conserving valuable network bandwidth. With MPEG-4 and MJPEG compatibility also included, video streams can also be transmitted in any of these formats for versatile applications. The streams can also be individually configured to meet different constraints, thereby further reducing bandwidth and storage requirements. Users can thus receive multiple streams simultaneously in different resolutions, frame rates, and image qualities for viewing on different platforms.

Its IP66-rated housing protects the camera body against rain and dust and ensures operation under poor weather conditions. Furthermore, the metal vandal-proof housing effectively provides robust protection from vandalism. Also included are a number of advanced features standard on Maxcom's cameras, including tamper detection, MicroSD/SDHC card slot, 802.3af compliant PoE (FD8134V), removable IR-cut filter and built-in IR illuminators, and Maxcom's 32-channel recording software. With all of these capabilities, the FD8133V/34V presents the best value in IP surveillance for indoor/outdoor applications.

Features

- > 1-Megapixel CMOS Sensor
- > Removable IR-cut Filter for Day and Night Function (FD8134V)
- > Built-in IR Illuminators, Effective up to 10 Meters (FD8134V)
- > Real-time H.264, MPEG-4 and MJPEG Compression (Triple Codec)
- > Vandal-proof IK10-rated and Weather-proof IP66-rated Housing
- > Built-in 802.3af Compliant PoE (FD8134V)
- > Built-in MicroSD/SDHC Card Slot for On-board Storage
- > 3-axis Mechanical Design for Ceiling and Wall Mount Installation
- > Easy and Flexible Installation
- > Compact and Attractive Design

Models	<ul style="list-style-type: none"> · FD8133V (DC power) · FD8134V (PoE)
System	<ul style="list-style-type: none"> · CPU: TI DM365 SoC · Flash: 128MB · RAM: 256MB · Embedded OS: Linux 2.6
Lens	<ul style="list-style-type: none"> · Board lens, Fixed, f = 3.6 mm, F1.8 · Removable IR-cut filter for day & night function (FD8134V)
Angle of View	<ul style="list-style-type: none"> · 56° (horizontal) · 41° (vertical)
Shutter Time	<ul style="list-style-type: none"> · 1/5 sec. to 1/25,000 sec.
Image Sensor	<ul style="list-style-type: none"> · 1/4" CMOS sensor in 1280x800 resolution
Minimum Illumination	<ul style="list-style-type: none"> · 0.3 Lux @ F1.8 (FD8133V) · 0 Lux @ F1.8 (IR LED on) (FD8134V)
IR Illuminators	<ul style="list-style-type: none"> · Built-in IR illuminators, effective up to 10 meters · IR LED*8 (850nm)
Video	<ul style="list-style-type: none"> · Compression: H.264, MJPEG & MPEG-4 · Streaming: <ul style="list-style-type: none"> Multiple simultaneous streams H.264 streaming over UDP, TCP, HTTP or HTTPS MPEG-4 streaming over UDP, TCP, HTTP or HTTPS H.264/MPEG-4 multicast streaming MJPEG streaming over HTTP or HTTPS · Supports activity adaptive streaming for dynamic frame rate control · Supports 3GPP mobile surveillance · Frame rates: <ul style="list-style-type: none"> H.264: <ul style="list-style-type: none"> Up to 30 fps at 1280x800 MPEG-4: <ul style="list-style-type: none"> Up to 30 fps at 1280x800 MJPEG: <ul style="list-style-type: none"> Up to 30 fps at 1280x800
Image Settings	<ul style="list-style-type: none"> · Adjustable image size, quality and bit rate · Time stamp and text caption overlay · Flip & mirror · Configurable brightness, contrast, saturation, sharpness, white balance and exposure · AGC, AWB, AES · Automatic, manual or scheduled day/night mode (FD8134V) · BLC (Backlight Compensation) · Supports privacy masks
Networking	<ul style="list-style-type: none"> · 10/100 Mbps Ethernet, RJ-45 · Onvif support · Protocols: IPv4, IPv6, TCP/IP, HTTP, HTTPS, UPnP, RTSP/RTP/RTCP, IGMP, SMTP, FTP, DHCP, NTP, DNS, DDNS, PPPoE, CoS, QoS, SNMP, and 802.1X
Alarm and Event Management	<ul style="list-style-type: none"> · Triple-window video motion detection · Tamper detection · One D/I for external sensor · Event notification using HTTP, SMTP or FTP · Local recording of MP4 file
On-board Storage	<ul style="list-style-type: none"> · MicroSD/SDHC card slot · Stores snapshots and video clips

Security	<ul style="list-style-type: none"> · Multi-level user access with password protection · IP address filtering · HTTPS encrypted data transmission · 802.1X port-based authentication for network protection
Users	<ul style="list-style-type: none"> · Live viewing for up to 10 clients
Dimension	<ul style="list-style-type: none"> · Camera: Ø 133 mm x 94 mm · Cable length: 500 mm · Cable diameter: Ø 7.8 mm; Max width: Ø 24 mm
Weight	<ul style="list-style-type: none"> · Net: 602.5 g (FD8133V) · Net: 623.5 g (FD8134V)
LED Indicator	<ul style="list-style-type: none"> · System power and status indicator · System activity and network link indicator
Power	<ul style="list-style-type: none"> · 12V DC · Power consumption: <ul style="list-style-type: none"> Max. 3.5 W (FD8133V) Max. 4.5 W (FD8134V) · 802.3af compliant Power-over-Ethernet (Class 2) (FD8134V)
Housing	<ul style="list-style-type: none"> · Vandal-proof IK10-rated metal housing · Weather-proof IP66-rated housing
Approvals	<ul style="list-style-type: none"> · CE, LVD, FCC, VCCI, C-Tick
Operating Environments	<ul style="list-style-type: none"> · Temperature: 0 ~ 50 °C (32 ~ 122 °F) · Humidity: 90% RH
Viewing System Requirements	<ul style="list-style-type: none"> · OS: Microsoft Windows 7/Vista/XP/2000 · Browser: Mozilla Firefox, Internet Explorer 6.x or above · Cell phone: 3GPP player · Real Player: 10.5 or above · Quick Time: 6.5 or above
Installation, Management, and Maintenance	<ul style="list-style-type: none"> · 3-axis mechanism for flexible ceiling and wall mount installation · Camera angle adjustment: pan 350° , tilt 85° , rotate 350° · Installation Wizard 2 · 32-CH ST7501 recording software · Supports firmware upgrade
Applications	<ul style="list-style-type: none"> · SDK available for application development and system integration
Warranty	<ul style="list-style-type: none"> · 24 months

Dimension

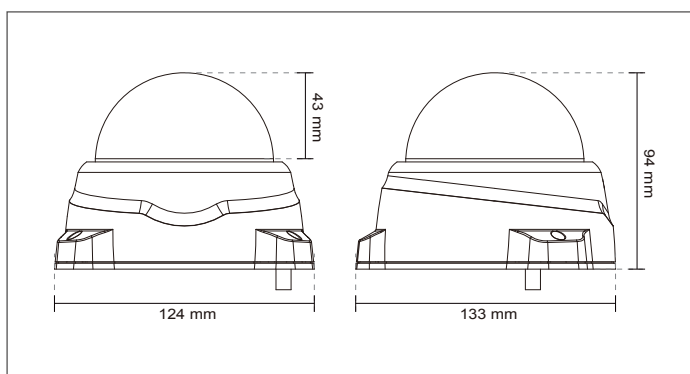

All specifications are subject to change without notice. Copyright © 2011 VIVOTEK INC. All rights reserved. P/N: 971004100

Distributed by:



Tel: +971 4 3525008 /09

E-mail: sales@maxcom.ae

