



FEATURES

- 1/3" High Sensitivity CCD
- Ultra High Resolution : 600 TV Lines (BW 650TV Lines)
- Built-in DC Iris Vari-focal Lens(f=2.8~10.5mm)
- TDN(ICR)
- Min. Illumination : 0.01Lux (B/W)
- OSD, Auto White Balance
- AGC, SBLC, Flickerless
- Motion Detection, Privacy Zone, Mirror Function
- 3-Axis Movement for Free Lens Rotation
- (Option) RS-485(Pelco-D, CNB) Interface
- 12VDC

Avail. in optional models

- DBM-24VF / DBM-25VF : 24VAC/12VDC Dual Voltage
- DBM-24VD / DBM-25VD : Varifocal Lens(4~9mm), without TDN(ICR)
- DBM-20VD / DBM-21VD : Varifocal Lens(4~9mm), without TDN(ICR)
- DBM-20S / DBM-21S : Fixed Lens(3.8mm), without TDN(ICR)

Accessories (Order Separately)

- WDB203 : Wall Mount Bracket
- PDB103 : Pendant Mount Bracket



Dimension

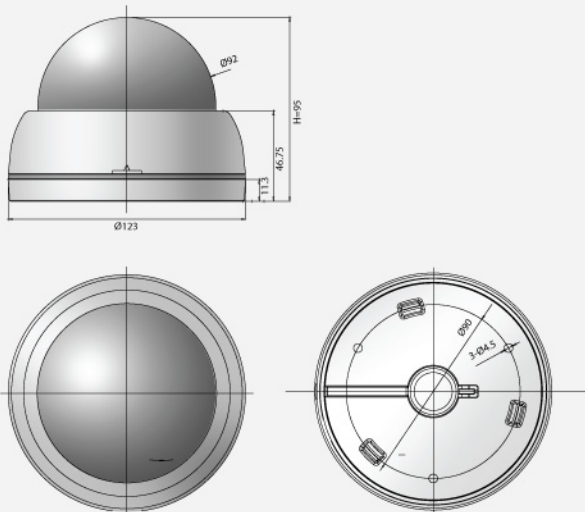

Specification

Model	DBM-20VF	DBM-21VF
Signal System	NTSC	PAL
Scanning System	2:1 Interface	
Scanning Frequency(H)	15.734KHz	15.625KHz
Scanning Frequency(V)	59.94Hz	50Hz
Image Sensor	1/3" High Sensitivity CCD	
Sync. System	Internal	
Total Pixels Number	811(H) x 508(V) 410K	795(H) x 596(V) 470K
Effective Pixels Number	768(H) x 494(V) 380K	752(H) x 582 (V) 440K
Horizontal Resolution	600 TV Lines (BW 650TV Lines)	
Video Output Level	1.0 Vp-p (75Ω, Composite)	
S/N Ratio	More than 50dB (AGC Off)	
Lens	DC Iris Vari-focal Lens (f=2.8~10.5mm)	
Min. Illumination	0.1 Lux (Color), 0.01 Lux (B/W), F1.2, 30IRE	
Day & Night System	ICR(AGC Type)	
Digital Noise Reduction (SDNR)	Low, Middle, High, Off	
White Balance	ATW, Manual, Push	
AGC	On/Off	
SBLC	Off, Low, Middle, High	
Flickerless	On/Off	
OSD Menu	English, Chinese	
Mirror Function	Horizontal	
Privacy Zone	On/Off (4 Programmable Zone)	
Motion detection	On/Off (4 Programmable Zone)	
Electronic Shutter Speed	1/60~1/120,000sec	1/50~1/120,000sec
Manual Shutter Speed	1/60, 1/250, 1/700, 1/1K, 1/1.6K, 1/2.5K, 1/5K, 1/7K, 1/10K, 1/30K, 1/60K, 1/120K	1/50, 1/250, 1/700, 1/1K, 1/1.6K, 1/2.5K, 1/5K, 1/7K, 1/10K, 1/30K, 1/60K, 1/120K
Power Voltage	12VDC (10V~15V)	
Power Consumption	Max. 2.2W / 180mA	
Dimensions	92(Ø) x 95(H) mm	
Weight (Net)	Approx. 366g	